

Masted
forklift truck

MSI 20 T/25 T
■ **MSI 30 T/35 T**
Evolution

- Standard lifting height : 3.30 m
- Nominal capacity : 2000/2500/3000/3500 kg
- Perkins Turbo engine : 60 HP - 44.7 kw
- Hydrostatic transmission



* Non contractual picture

MSI: MANITOU exclusive design

The MSI is a range of semi-industrial trucks with a capacity from 2 to 3.5 tonnes that are particularly manoeuvrable and flexible to use. It is stable and multi-purpose to enable it to work in both outside and indoor storage areas whether or not the ground has been consolidated.

• Direct access to the driver's compartment

To make life easier for the operator who is continually getting in and out of the cab MANITOU has designed a truck that can be accessed from either side with no step to climb.

The extremely compact MSI is available in the standard version that has an overall height of 2.10 m to the top of the cab or in the Buggie version just 1.99 m high.



• Exceptionally flexible in use

The design with large front wheels combined with hydrostatic transmission gives the MSI appreciably greater flexibility when driving on unfinished ground. The low pressure pneumatic tyres absorb the jolts that occur when driving over kerbs, pot-holes etc. and give good road-holding when driving on slippery ground.



The MSI is also extremely stable when laden/unladen and has a very short turning radius achieved by its new steering axle with integral steering cylinder.

• Robust components

The MANITOU manufactured solid bloc chassis and the components on the MSI are well engineered and treated against corrosion for an exceptionally long life.

• Ergonomically designed spacious driver's compartment

The MSI's suspended driver's compartment insulates the driver from vibrations.

In the optional enclosed cab version, the adjustable steering column, the fabric-covered seat suspended on hydraulic shock-absorbers and ventilated heating all add to comfort.



Standard seat



Comfort seat with closed cab



A single lever close to the seat brings together the operations to lift, lower and tilt the mast (10°/12°).

The MSI has an **automatic system to accelerate lifting the mast** which is independent of travel mode.

• Precise handling with hydrostatic transmission

Hydrostatic transmission offers **smooth and efficient handling accurately** and in complete safety.

Dynamic double braking system:

- braking by deceleration of the hydrostatic transmission
- dynamic braking with oil bath multidisc brakes

When parking, the braking is carried out partly by the negative brake (automatic when the engine stops).

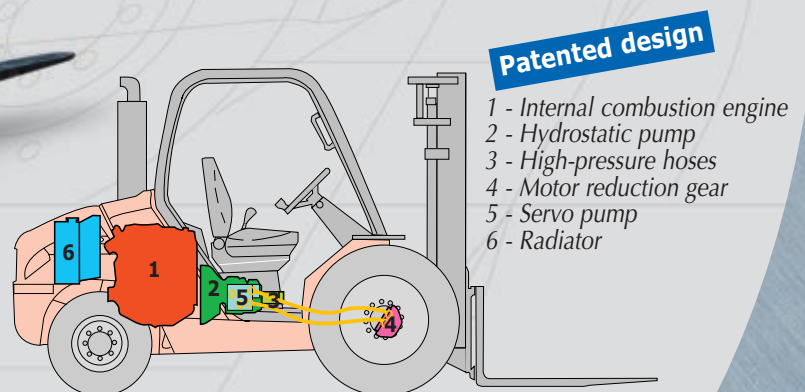

• Easy maintenance

The MSI gives exceptionally easy access to the engine components simplifying maintenance operations.

An electro-hydraulic power unit **effortlessly tilts the cab forward**.



You can choose from the MSI 20, 25, 30, 35

MANITOU offers models in a diesel version: MSI 20 T, MSI 25 T, MSI 30 T, MSI 35 T, or in a gas version: MSI 20 G, MSI 25 G, MSI 30 G to suit your kind of business.

These models are also offered in a Buggie version (1.99 m overall height).



MSI 30 T
with fork locator.

In industry the MSI-G is the answer to handling in a closed environment (mushroom houses, greenhouses etc.). In logistics, the MSI-G Buggie is an effective handling tool for loading or unloading lorries.



MSI 30 G with fixed reservoir
(standard version with gas bottle).



MSI 20 T Buggie
with re-handling bucket.

MSI - G:

(2 to 3 tonnes) the 4-cylinder TOYOTA 4Y single fuel gas engine, develops 53 hp/39 kW at a nominal engine speed of 2200 rpm. This reliable and powerful engine is distinguished by not emitting soot, and reduced fuel consumption.

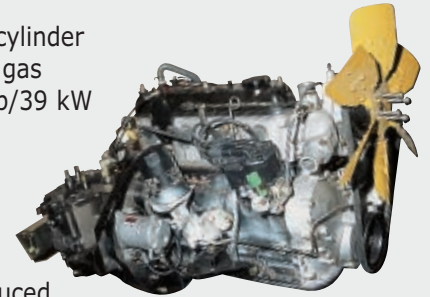

MSI - T:

Perkins motor 4 cylinder 404 C 22 T develops 60 hp/44.7 kW at a nominal engine speed of 2800 rpm.

These engines are a combination of advanced technology and long experience.

These reliable and robust engines are designed to operate cleanly, in compliance with anti-pollution regulations.



MSI 30 T
cab with 4-fork
arrangement.



MSI 30 T
cab with rotating grab with reels.

models

• The tilting carriage: perfect versatility

The tilting carriage is an option that can be adapted for MSI trucks from 2 to 3.5 tonnes fitted with Duplex masts with All-round Vision (DVT). Adaptation for the T.I. carriage is carried out in the MANITOU factory.



Option

The advantages of the T.I.

- Quick change for attachments.
- Increased performance using the forward tilt.
- A tilt angle of 66° enables a re-handling bucket to be used.
- Makes possible the use of a wide range of MANITOU attachments.
- Hydraulic locking in option.



Adapting to fit the T.I. carriage changes the truck's load chart- Please consult us.

The tilting carriage with sideshift

The tilting carriage with sideshift (T.I.D.L.) can be adapted for MSI trucks from 2 to 3 tonnes fitted with DVT masts. The T.I.D.L. brings together the Tilting carriage (T.I.) and the Sideshift carriage (T.D.L.) operations. Adaptation for the T.I.D.L is carried out in the MANITOU factory.

A NEW IDEA FROM
MANITOU



Option



The advantages
of the T.I.D.L.

- Precise loading of pallets up to 100 mm movement on each side.
- Integral permanent sideways movement without loss of extra capacity*.
- Fast changing of attachments.
- Hydraulic locking in option.

* The same load chart as a truck fitted with T.I. depending on the model.



Hydraulic
locking.



Manitou have the answer to your handling problems increasing versatility and your MSI's speed of operation.

MSI 20 - 25 - 30 - 35 masts

	MASTED MODEL	TYPE OF TRUCK	TOTAL LIFT	OVERALL MAST FOLDED	FREE LIFTING	OVERALL MAST IN USE	HEIGHT AT MAXIMUM CAPACITY	CAPACITY AT MAXIMUM HEIGHT		TILT OF THE MAST
			(mm)	(mm)	(mm)	(mm)	(mm)	(kg)	Front/Rear	
ALL-ROUND VISION DUPLEX	3.00 m	MSI 20-25	3030	2150	130	3831	3000	2000 - 2500	2000 - 2500	10°/12°
		MSI 30-35	3035		135	3893		3000 - 3500	3000 - 3200	
	3.30 m	MSI 20-25	3330	2300	130	4131	3300	2000 - 2500	2000 - 2500	10°/12°
		MSI 30-35	3335		135	4193		3000 - 3500	3000 - 3200	
	3.50 m	MSI 20-25	3530	2400	130	4331	3500	2000 - 2500	2000 - 2500	10°/12°
		MSI 30-35	3535		135	4393		3000 - 3500	3000 - 3200	
	3.70 m	MSI 20-25	3730	2560	130	4531	3700	2000 - 2500	2000 - 2500	10°/12°
		MSI 30-35	3735		135	4593		3000 - 3500	3000 - 3200	
4.00 m	MSI 20-25	4030	2750	130	4831	4000	2000 - 2500	2000 - 2500	10°/12°	
	MSI 30-35	4035		135	4893		4000 - 3700	3000 - 3400		2800 - 3100
4.50 m	MSI 20-25	4530	3000	130	5331	4000	1800 - 2200	1600 - 2200	10°/12°	
	MSI 30-35	4535		135	5393		4000 - 3700	2700 - 3100		2500 - 3100
5.00 m	MSI 20-25	5030	3250	130	5831	4000	1500 - 1900	1300 - 1600	6°/6°	
	MSI 30-35	5035		135	5893		4000 - 3700	2400 - 2800		2000 - 2700
FREE LIFTING DUPLEX	3.00 m	MSI 20-25	3040	2150	1393	3797	3000	2000 - 2500	2000 - 2500	10°/12°
		MSI 30-35	3045		1396	3799		3005	3000 - 3500	
	3.30 m	MSI 20-25	3340	2300	1543	4097	3300	2000 - 2500	2000 - 2500	10°/12°
		MSI 30-35	3345		1546	4099		3300	3000 - 3500	
	3.50 m	MSI 20-25	3540	2400	1643	4297	3500	2000 - 2500	2000 - 2500	10°/12°
MSI 30-35		3545	1646		4299	3500		3000 - 3500	3000 - 3200	
3.70 m	MSI 20-25	3740	2560	1803	4497	3700	2000 - 2500	2000 - 2500	10°/12°	
	MSI 30-35	3745		1806	4499		3700	3000 - 3500		3000 - 3200
4.00 m	MSI 20-25	4040	2750	1993	4797	4000	2000 - 2500	2000 - 2500	10°/12°	
	MSI 30-35	4045		1996	4799		4000 - 3700	3000 - 3400		2800 - 3100
ALL-ROUND VISION TRIPLEX	3.30 m	MSI 20-25	3340	1840	-	4070	3300	2000 - 2500	2000-2500	10°/12
FREE LIFTING TRIPLEX	3.70 m	MSI 20-25	3740	1950	1221	4469	3700	2000 - 2500	2000 - 2500	10°/12°
		MSI 30-35	3745	2050	1297	4500		3700	3000 - 3500	
	4.00 m	MSI 20-25	4040	2050	1321	4769	4000	2000 - 2500	2000 - 2400	10°/12°
		MSI 30-35	4045	2150	1397	4800		4005	3000 - 3500	
	4.30 m	MSI 20-25	4340	2150	1421	5069	4300 - 4000	2000 - 2400	1900 - 2200	10°/12°
		MSI 30-35	4345	2300	1547	5100		4000	2800 - 2900	
	4.70 m	MSI 20-25	4740	2300	1571	5469	4000	1700 - 2100	1500 - 1900	10°/12°
		MSI 30-35	4745	2400	1647	5500		4000	2600 - 2400	
5.00 m	MSI 20-25	5040	2400	1671	5769	4040	1500 - 1900	1300 - 1600	6°/6°	
	MSI 30-35	5045	2560	1807	5800		4000	2400 - 2800		2000 - 2500
5.50 m	MSI 20-25	5540	2560	1831	6269	4000	1300 - 1500	1000 - 1200	6°/6°	
	MSI 30-35	5545	2750	1997	6300		4000	1900 - 2300		1500 - 1200
6.00 m	MSI 20-25	6040	2750	2021	6769	4000	1000 - 1200	600 - 800	6°/6°	
	MSI 30-35	6045	3000	2247	6800		4000	1500 - 1900		1100 - 1600

MSI 20 - 25 - 30 load charts Diesel and Gas

• MSI width with tyres 1320 mm (with TDL)

• MSI width with tyres 1320 mm (without TDL)

MSI 20 T/G

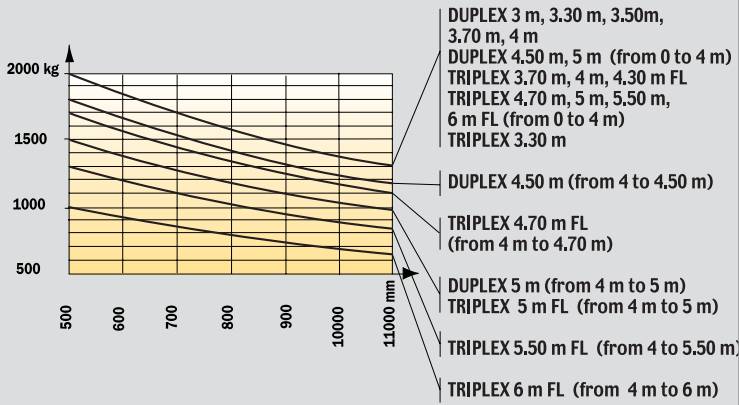

MSI 20 T/G

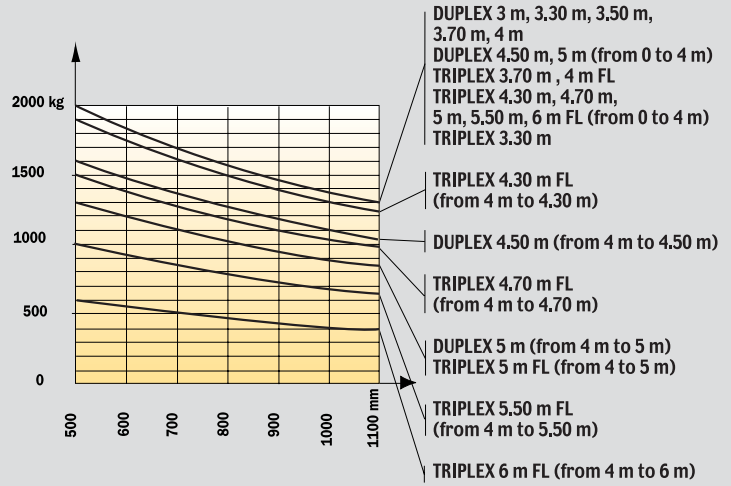

MSI 25 T/G

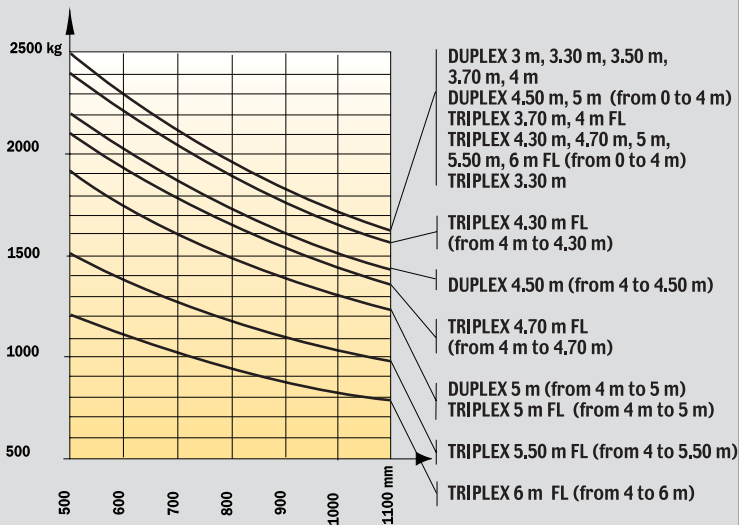

MSI 25 T/G

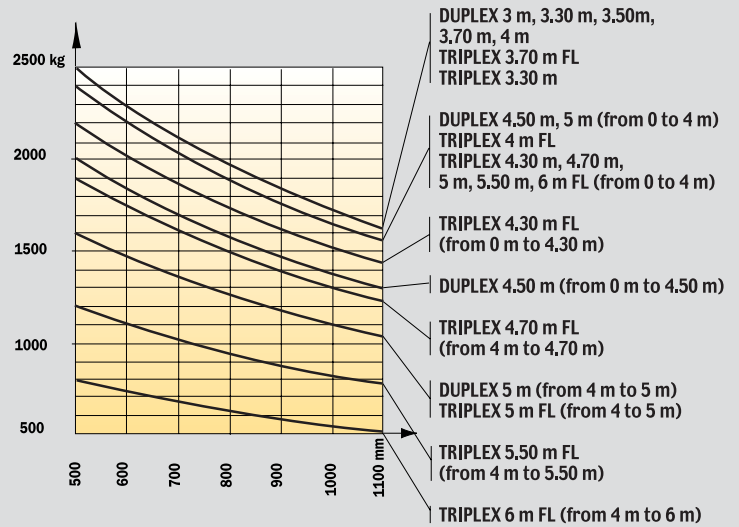

MSI 30 T/G

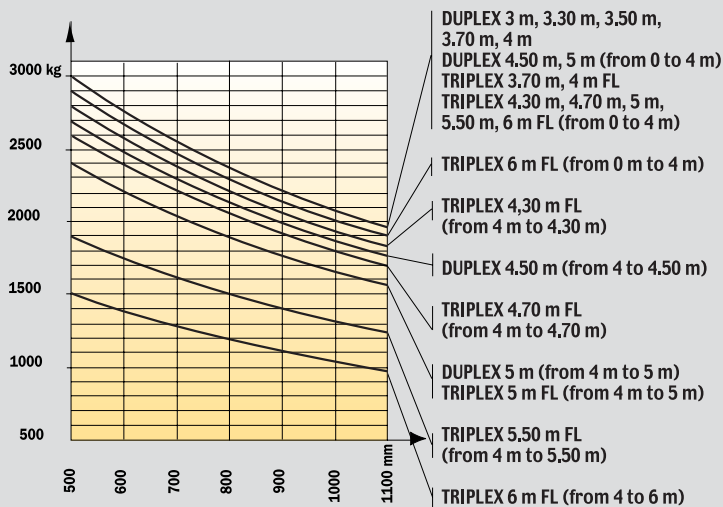

MSI 30 T/G

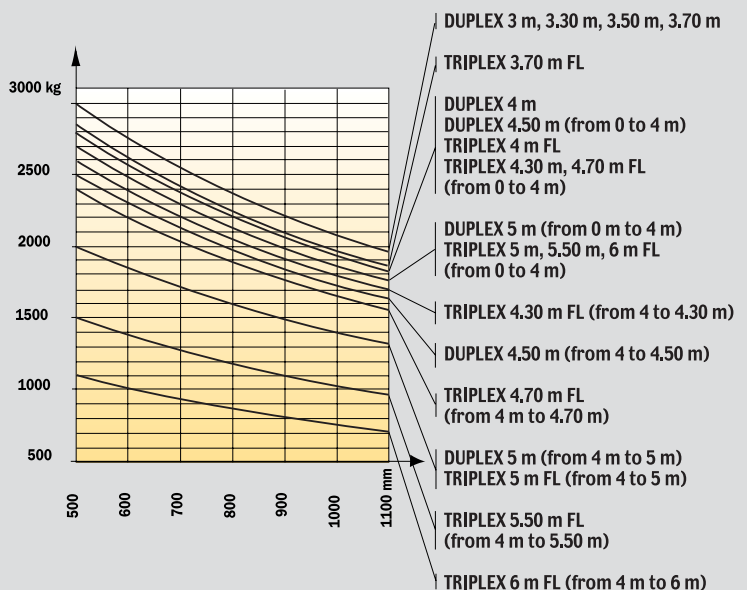

MSI 20 - 25 - 30 load charts Diesel and Gas

• MSI width with tyres 1500 mm (without TDL)

• MSI width with tyres 1500 mm (with TDL)

MSI 20 T/G

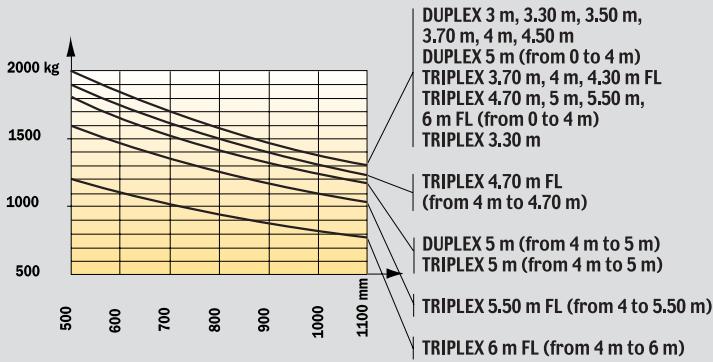

MSI 20 T/G

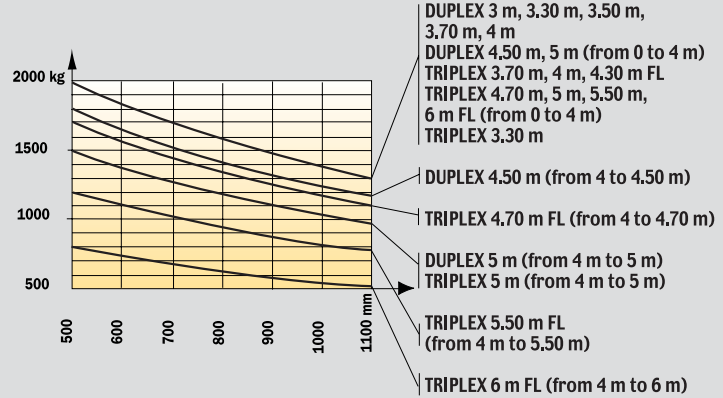

MSI 25 T/G

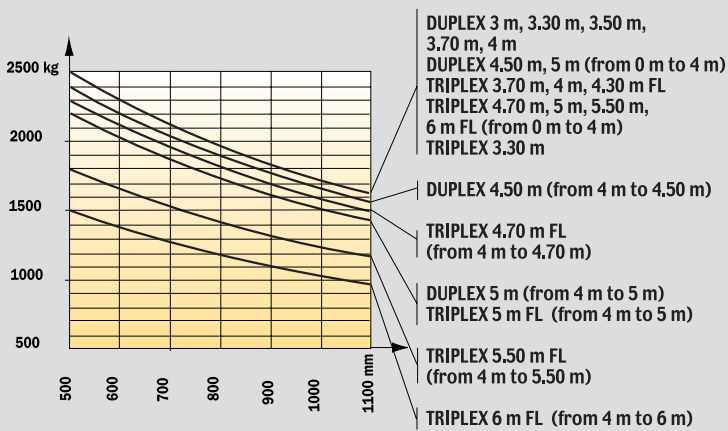

MSI 25 T/G

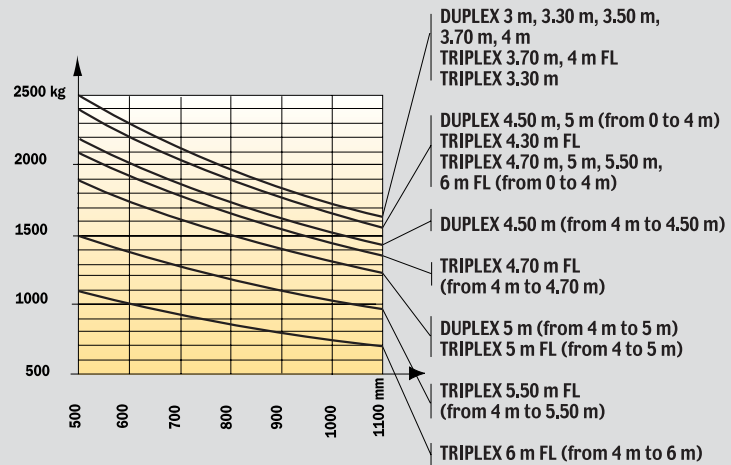

MSI 30 T/G

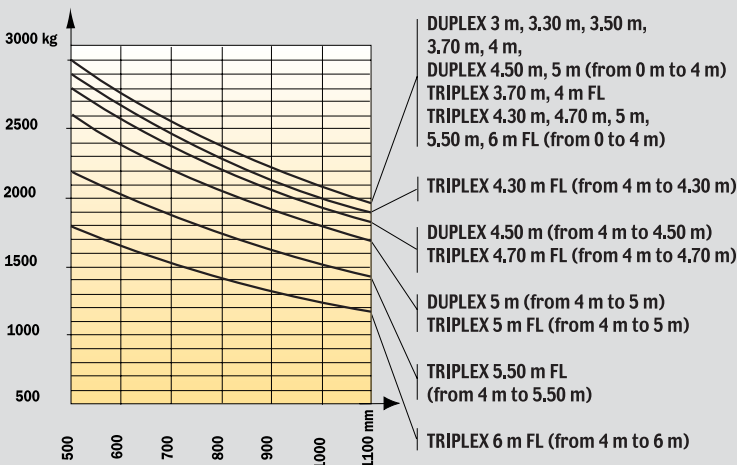

MSI 30 T/G

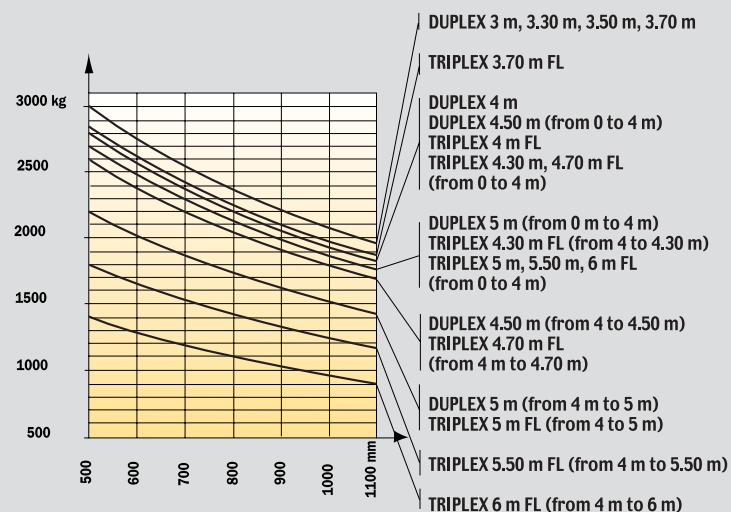

MSI 35 T load charts (Diesel only)

• MSI width with tyres 1320 mm (without TDL)

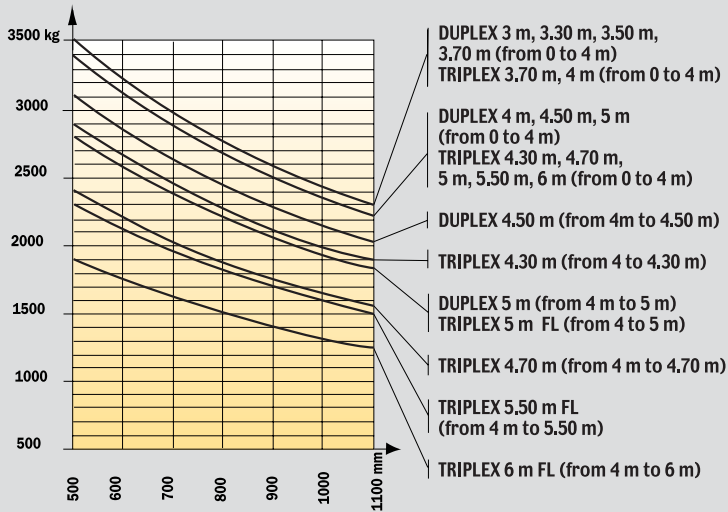

• MSI width with tyres 1320 mm (with TDL)

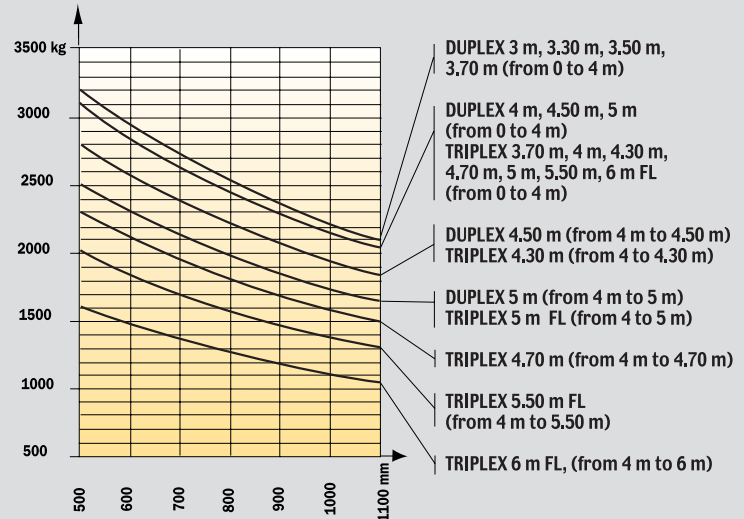



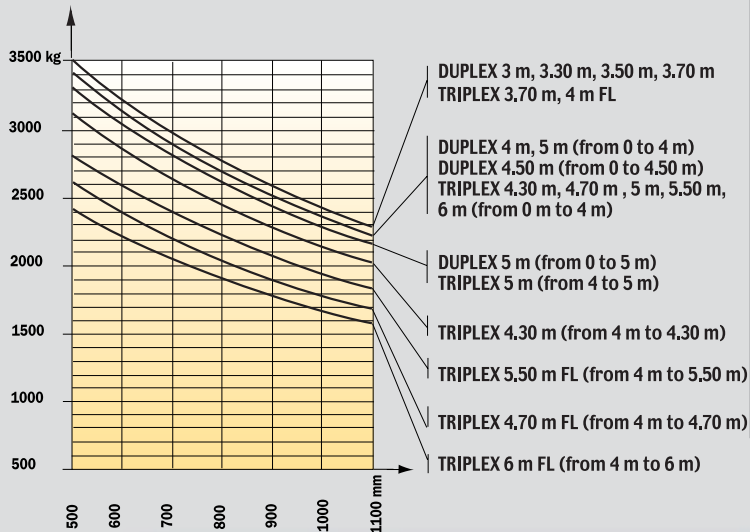



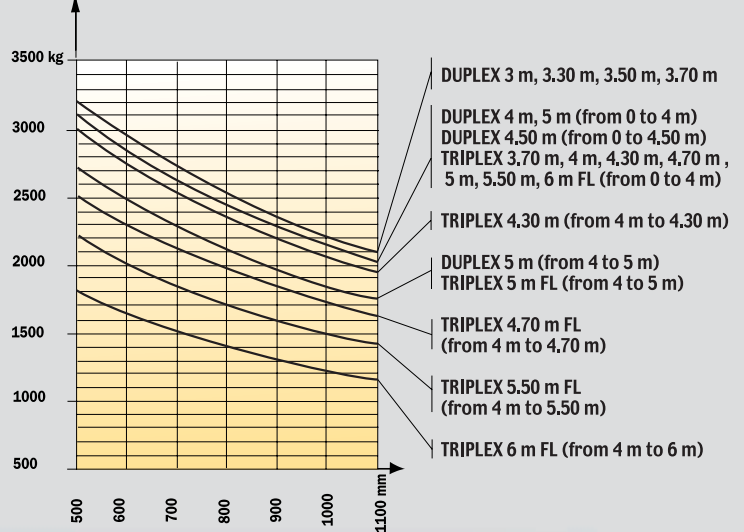







• MSI width with tyres 1500 mm (without TDL)



• MSI width with tyres 1500 mm (with TDL)



Tyres MSI 20 T/G - 25 T/G - 30 T/G - 35 T

	Versions		Casing	Tyre width (mm)	Overall machine width (mm)	
Standard fitting	Industrial	AV	275/70 R22.5 RHS GOOD YEAR	277	1323	
		AR	7.00 x 12 14 PR IC 40 CONTINENTAL	192	1294	
Optional fitting	Wide industrial	AV	275/70 R22.5 RHS GOOD YEAR	277	1523	
	All-purpose or Industrial	AR	27 - 10 - 12 14 PR IC 12 CONTINENTAL *	252	1393	
	Industrial	AR	700 R12 136 A5 XZM MICHELIN	191	1293	
	Flexible solid tyre	AV	8.25 - 20 - CSE SC 15 CONTINENTAL	253	1310	
		AR	7.00 - 12 CSE SC 10 CONTINENTAL	207	1309	
	All-purpose (except 3.5 T)	AV	10.5 R20 14 PR MPT 80 134 G CONTINENTAL	266	1322	
		AV	12. 0 x 18 12PR T 86 DUNLOP	309	1423	
	Wide all-purpose	AV	10.5 R 20 14PR MPT 80 134 G CONTINENTAL	266	1522	
		AV	15.5/55 R 18 SP PG 7 14 PR DUNLOP	374	1540	
	Extra wide all-purpose	AV	15.5/55 R 18 SP PG 7 14 PR DUNLOP (A)	374	1650	
	Field (2 T/2.5 T only)	AV	275/80 R20 XM 27 MICHELIN	280	1336	
Field (only on 2 T)	AR	195 R 14 C SPLT 30 DUNLOP	198	1290		

(A) Optional snow chains * With front width higher than 1500 mm

MSI 20/25/30/35 T MSI 20/25/30 G



Load capacity

at 500 mm load centre

MSI 20 T/G.....	2000 kg
MSI 25 T/G.....	2500 kg
MSI 30 T/G.....	3000 kg
MSI 35 T.....	3500 kg



Standard lifting height3.30 m



Tyres

Front.....275/70 R 22,5
Rear7.00 x 12



Forks (mm)

Length.....1100
Width x thickness100 x 45
Maximum space between forks1260



Hydraulic brakes



Perkins Turbo engine

Typ404 C 22T
Capacity4 cylindres 2216 cm³
Power (ISO TR 14396).....60 cv/44.7 kw
Maximum torque.....190 Nm at 1800 t/mn

Toyota LPG engine

MSI 20 G/25 G/30 G.....Type: 4 Y
Capacity4 cylindres 2237 cm³
Power (ISO TR 14396).....53 HP/39 kw
Maximum torque.....162 Nm at 1800 r.p.m.
Direct injection
Water cooling



HYDROSTATIC REXROTH Transmission

Wheel drive2
Electro-magnetic reversing shift
Speeds forward/reverse1/1
Maximum travel speed.....20 km/h



Hydraulic system

Steering pump125 bars/79 l/mn



Capacities

Cooling system10.5 l.
Engine oil.....9.75 l.
Hydrostatic transmission.....95 l.
Fuel tank73.5 l.



Weight (with forks)

MSI 20/25/30/35 T3840/4150/4530/4980 kg
MSI 20/25/30 G.....3470/4045/4425 kg

Overall width1.32 m
Overall height (mast lowered)2.30 m
Overall length4.04/4.04/4.08/4.13 m
Ground clearance215 mm

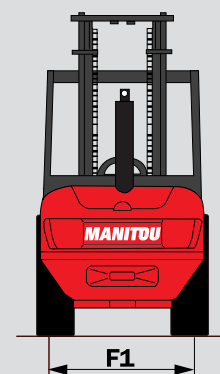
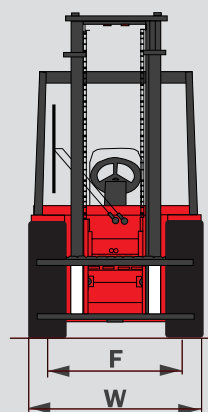
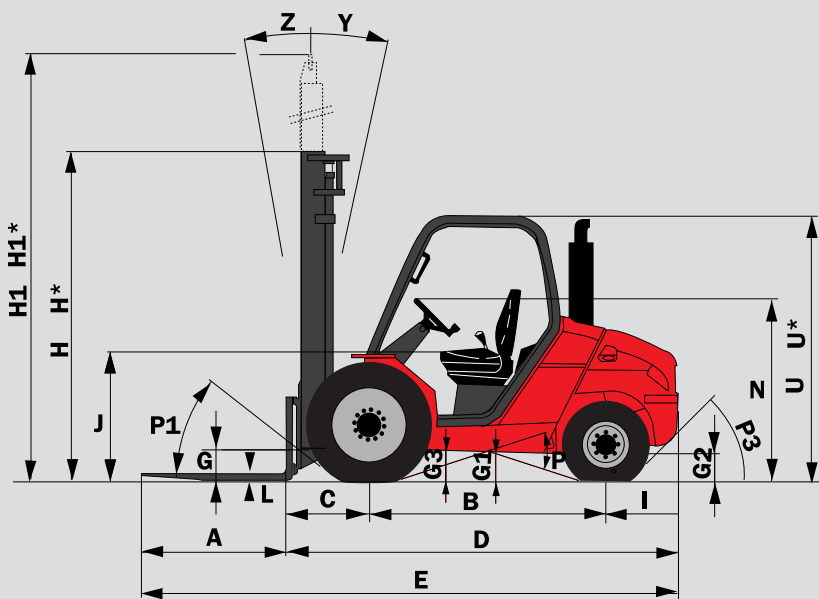

	MSI 20 T/G +BUGGIE	MSI 25 T/G +BUGGIE	MSI 30 T/G +BUGGIE	MSI 35 T +BUGGIE
A	1100	1100	1100	1100
B	1800	1800	1800	1800
C	625	625	630	630
D	2945	2945	2980	3030
E	4045	4045	4080	4130
F	1046	1046	1046	1046
F1	1102	1102	1102	1102
G	270	270	270	270
G*	240	240	240	240
G1	260	260	260	260
G1*	260	260	260	260
G2	215	215	215	215
G2*	230	230	230	230
G3	270	270	270	270
H	2300	2300	2300	2300
H*	1950	1950	2050	2050
H1	4131	4131	4193	4193
H1*	4470	4470	4500	4500
I	520	520	550	600
J	1025	1025	1025	1025
K	1260	1260	1260	1260
L	40	40	45	45
N	1450	1450	1450	1450
O	100	100	100	125
P1	49,5°	49,5°	49,5°	49,5°
P2	40,5°	40,5°	40,5°	49,5°
P3	44°	44°	40°	40°
R	2310	2310	2310	2330
S	2545	2545	2580	2590
T	4525	4525	4560	4595
U	2105	2105	2105	2105
U*	1990	1990	1990	1990
V	2600	2600	2635	2665
V1	150	150	150	100
W	1323	1323	1323	1323
Y	12°	12°	12°	12°
Z	10°	10°	10°	10°

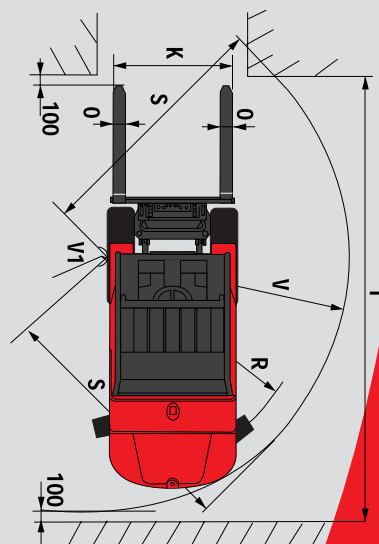

This equipment described in this leaflet may be standard, optional, or unavailable, depending on the versions. For more details, contact your MANITOU dealer.

H - H1 - R = Standard
H*-(Triplex 3,70 m) H1* = Option

U* = MSI 20/25 BUGGIE
G* - G1* - G2* = loaded



MANITOU BF SA

B.P. 249 - 44158 Ancenis Cedex - France
Tél. : 33 2 40 09 10 11 / Export Department Fax : 33 2 40 09 10 97
www.manitou.com

700314EN

